



14th International Conference on Aquatic Invasive Species



**Key Biscayne Florida
USA**



**Two Shipboard Demonstration of Chlorine
Dioxide to Control AIS:
Swedish flagged Ro/Ro Containership
And a US Flagged ITB Bulker**



Outline

- Vessel and installation specifics:
 - M/V Atlantic Compass
 - M/V Moku Pahu
- Ecochlor system review
- University Testing
- Summary

Atlantic Container Lines M/V Atlantic Compass





M/V Atlantic Compass

- Combination Ro/Ro Containership
- Ports of Call in Europe and North America
- Tonnage: 51,648 DWT
- Speed: 18 knots
- Effective Max Capacity: 3,100 TEUs
- Automobile Capacity: about 1,000 units
- Ballast water volume: about 10,000 m³ / 35 days
- BW max flow: ~ 2,500 m³ / hour



Installation

- Began in Antwerp, Belgium while sailing to Sweden
- Pipe work completed during the port call in Gothenburg
- Electrical installation began in Liverpool, England while sailing to Halifax, Nova Scotia
- Electrical / signal cable work in US ports
- System hydro-tested in US
- Chemicals loaded in Sweden

Matson Navigation M/V Moku Pahu





Installation

- Prepared for China or Singapore installation
- Actually installed in San Francisco dockside between charters
- Skin penetration completed with seven 8-hour shifts
- Pipe work, electrical, signal and chemical unloading completed during vessel lay-up
- System commissioned during subsequent port call in California



Summary

- Both system capacities are 2,500 m³ / hour
- Coordinated effort in 5 countries (Belgium, Sweden, UK, Canada, USA)
- Both system commissioned on schedule
- Atlantic Compass installation approved by Lloyd's Register
- Moku Pahu installation approved by ABS



Ecochlor System Review



Chlorine Dioxide

- Approved for drinking water, direct contact with food, numerous industrial applications
- Highly effective on all organisms, biofilm
- No effect on metals, coating, slight effect on water pH
- No formation of chlorinated by-products
- Cost effective even at high and very high flow rates
- No Chlorine Dioxide residuals discharged, environmentally acceptable

Chlorine Dioxide Decay (12°C)

ClO₂ Decay Rate
Baltimore, November 2004
Atlantic Compass, ballast tank 6DBP

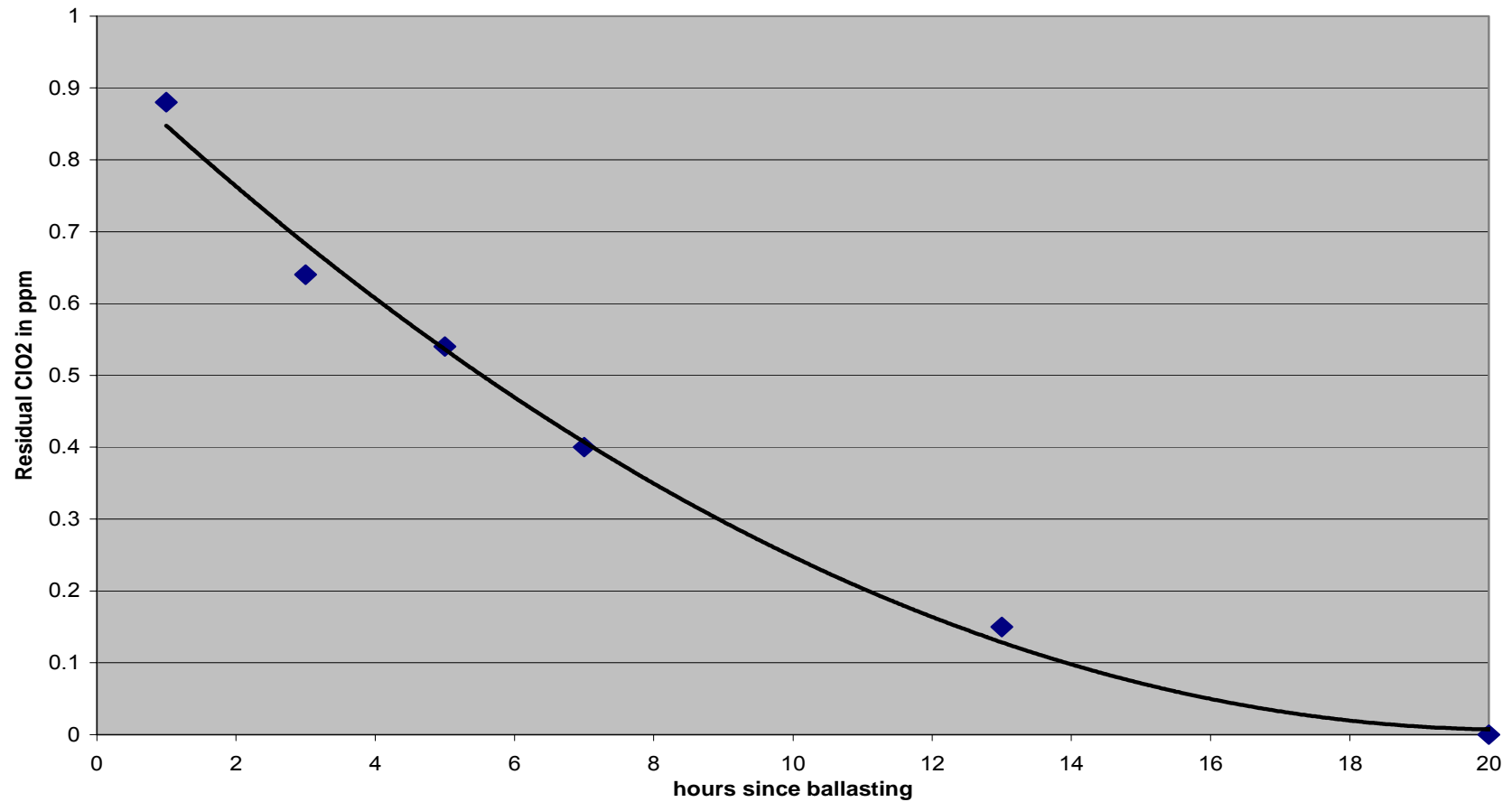

Chlorine Dioxide Decay (5°C)

ClO₂ Decay Rate
Baltimore, December 2004
Atlantic Compass, ballast tank 6DBP

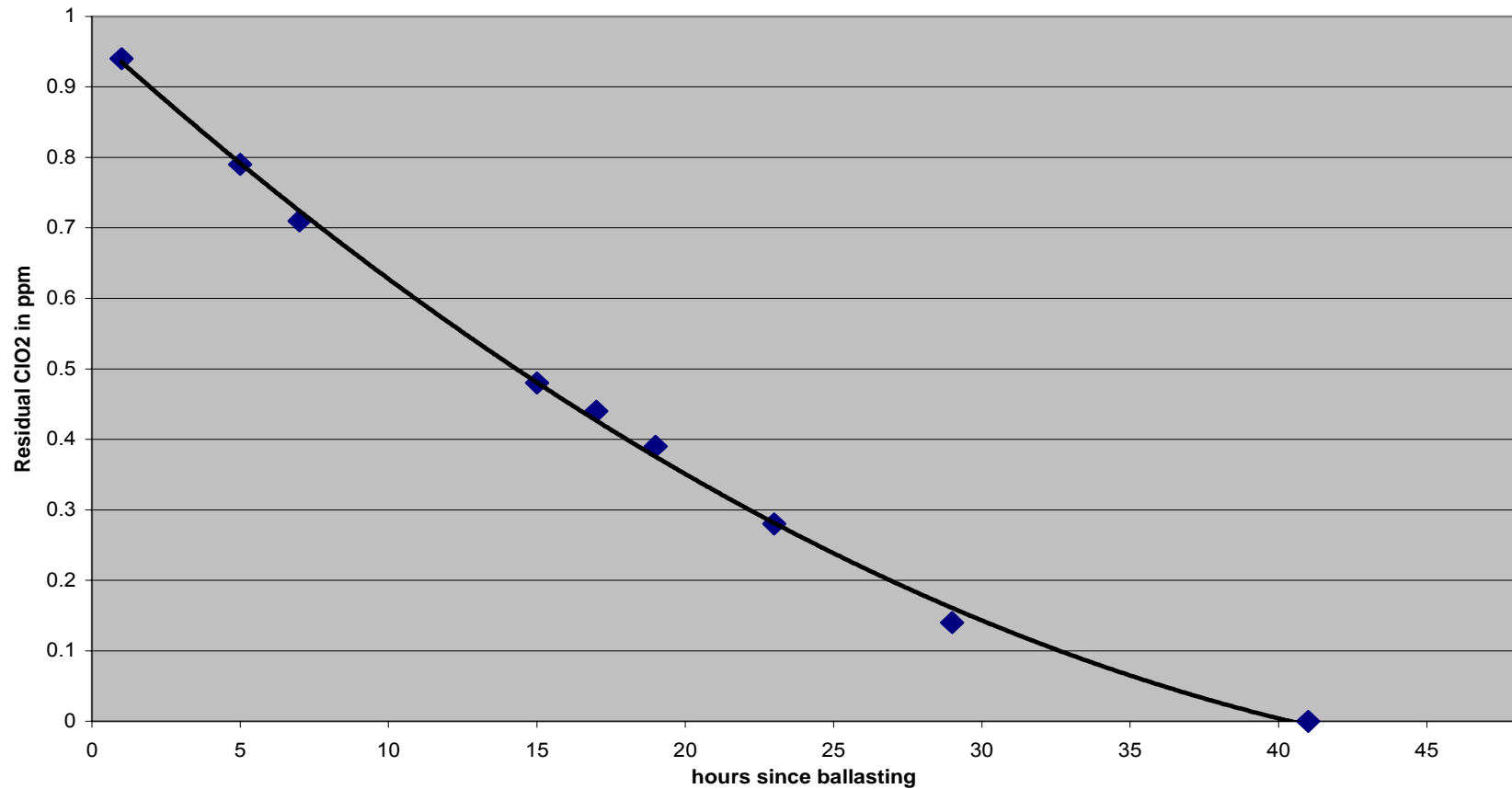

Chlorine Dioxide Decay (26°C)

CIO₂ Decay Rate
Djibouti Africa, December 2005
M/V Moku Pahu, #3 wing tank, starboard

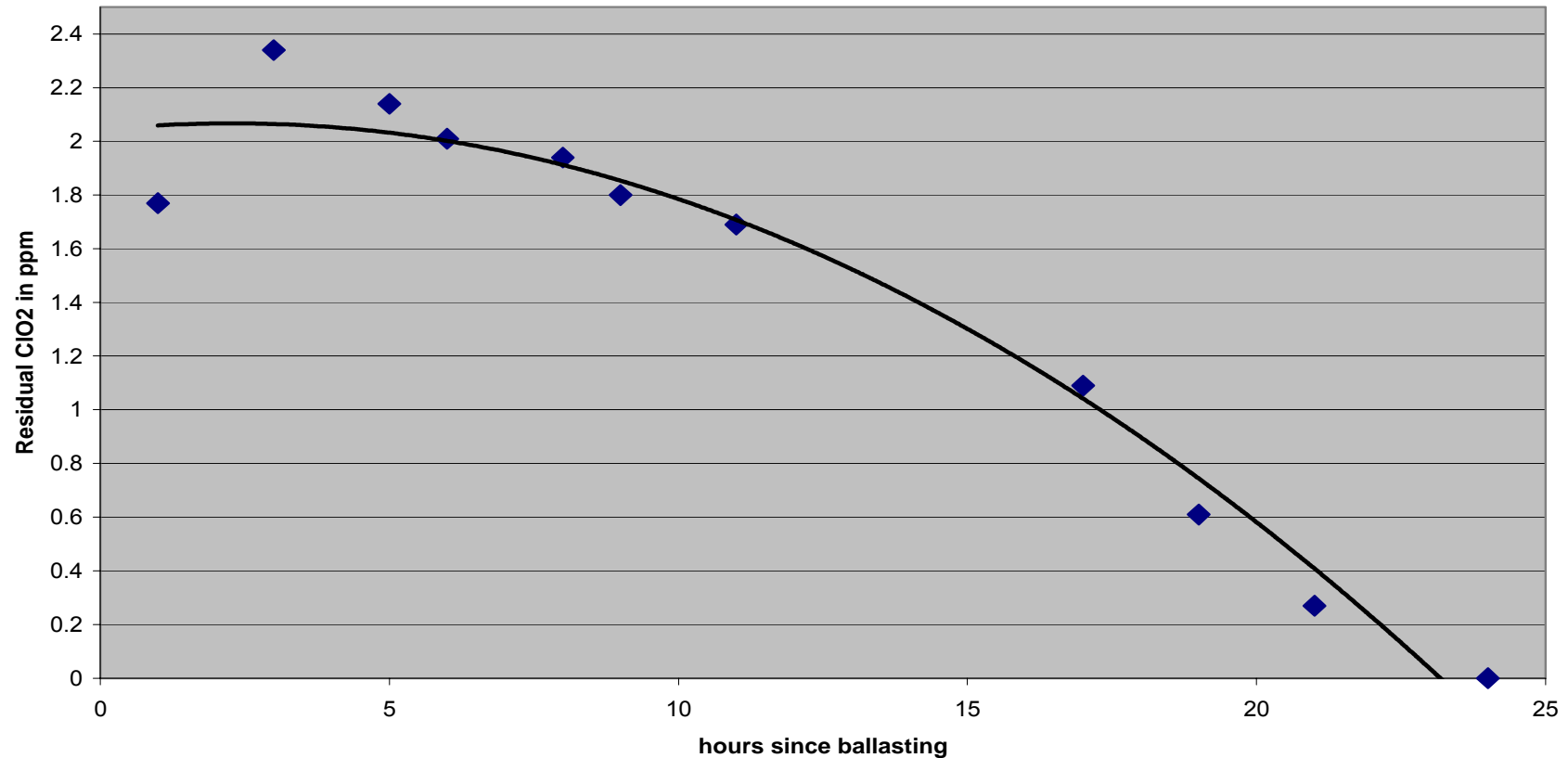



Chlorine Dioxide

The chemical reaction is as follows:

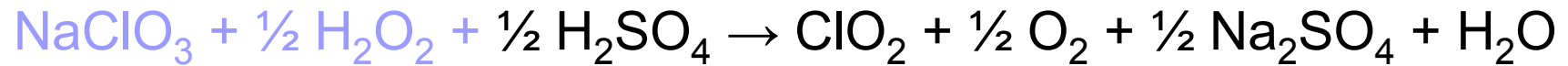

Pre-blended Purate® Solution



Chlorine Dioxide

The process is as follows:

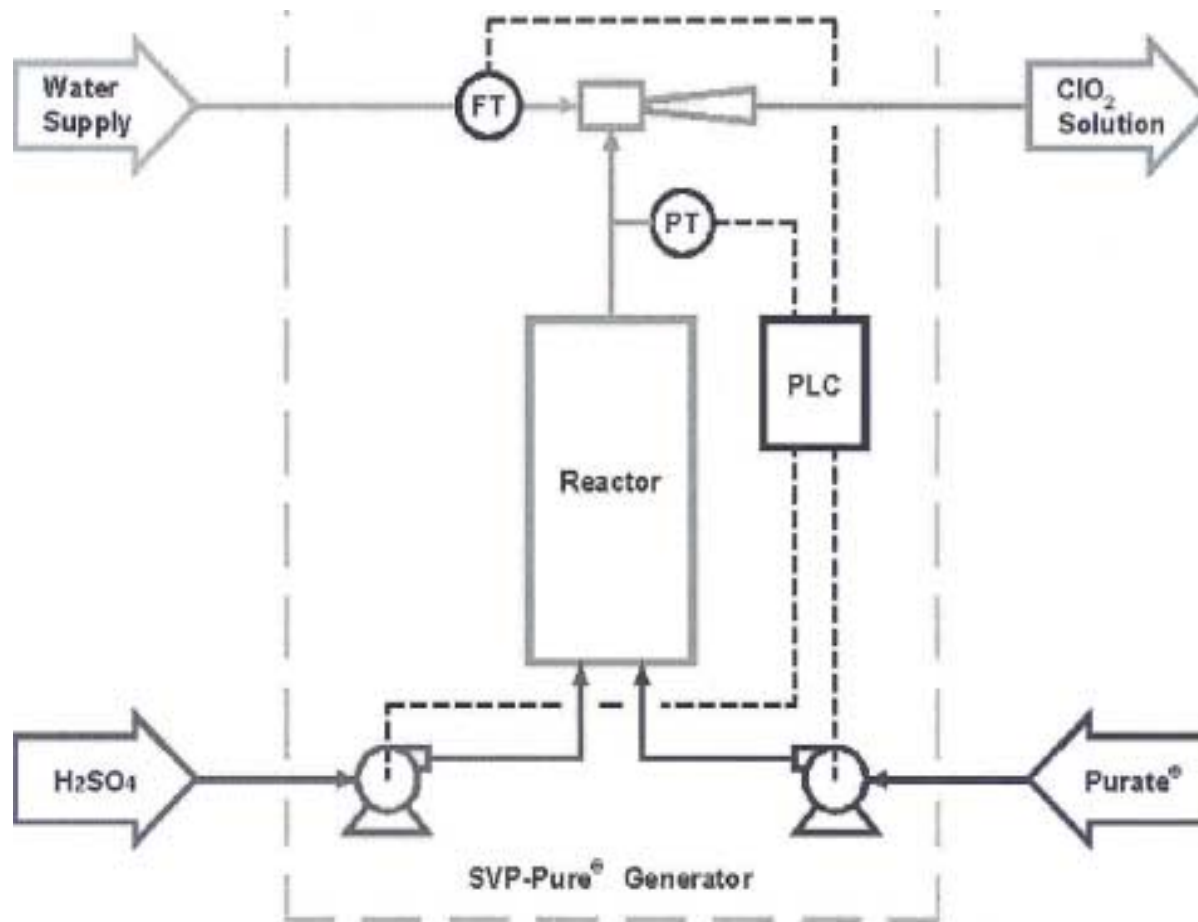



Ecochlor System

- Flexible system enclosure
- Fully automated, no crew interaction
- No changes to ballasting operations or rates
- Hastaloy / 316 SS construction
- Small footprint – 9 m² or 80 ft²



M/V Atlantic Compass



M/V Moku Pahu

Shipboard Test Results

University of Rhode Island

Graduate School of Oceanography

Conducted on the M/V Atlantic Compass





Test Results

Zooplankton greater than 50 micron / m³

	Time =0	12 hr	24 hr	48 hr	72 hr	96 hr
Control	7121	5703	6615	2945	2846	1901
Treatment	0	0	0	5	0	0

Species Identified (in decreasing concentration):

Calanoid copepod (*Acartia tonsa*)
Calanoid copepod (*Eurytemora* sp.)
Cyclopoid copepod (*Oithona similis*)
Harpacticoid copepods
Barnacle cyprindids

Test Results

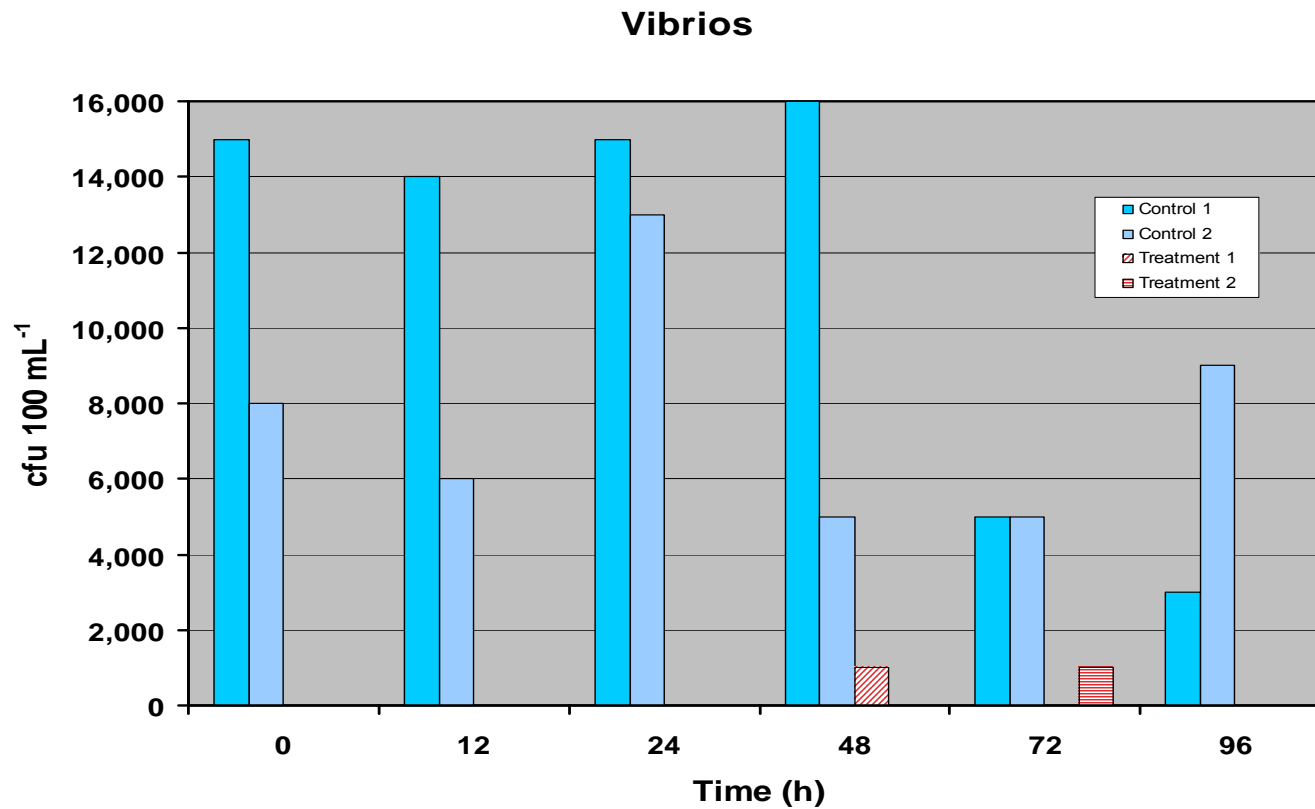

Test Results

E. Coli Colonies

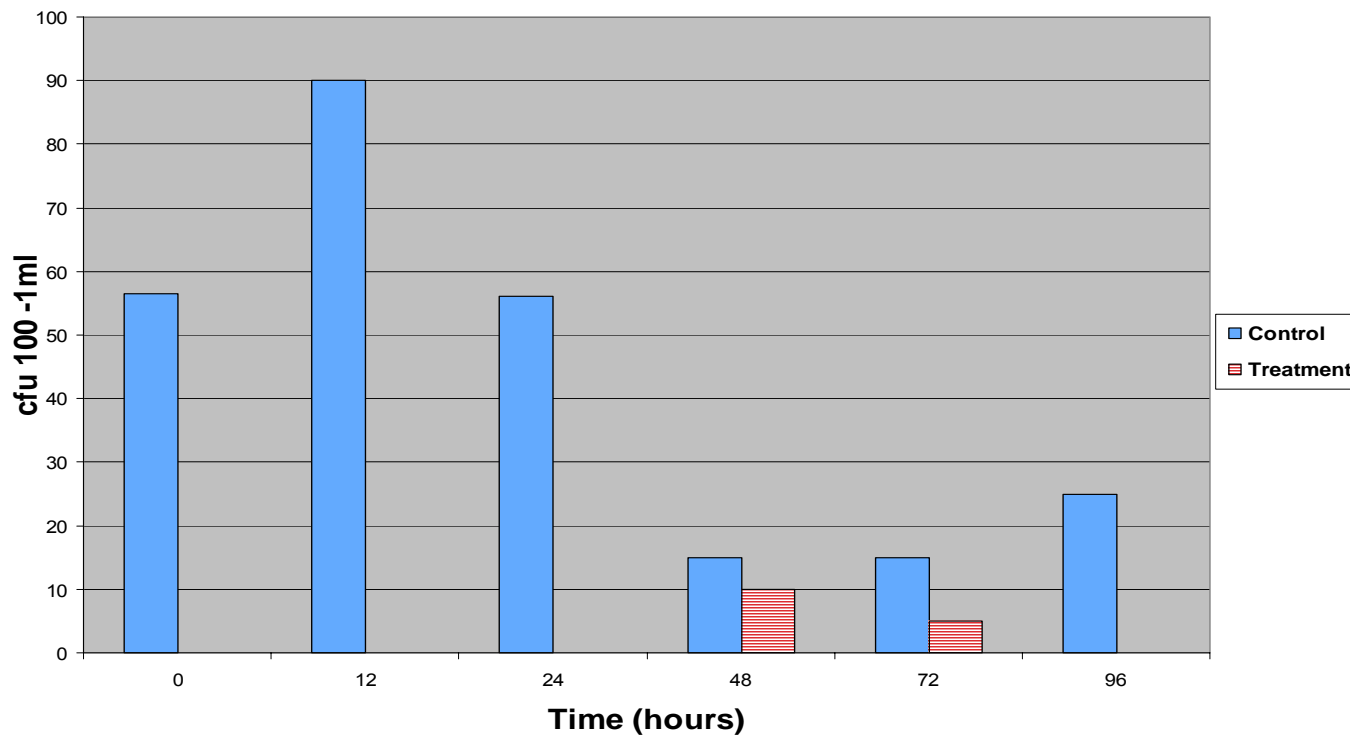

Test Results

Total Coliform

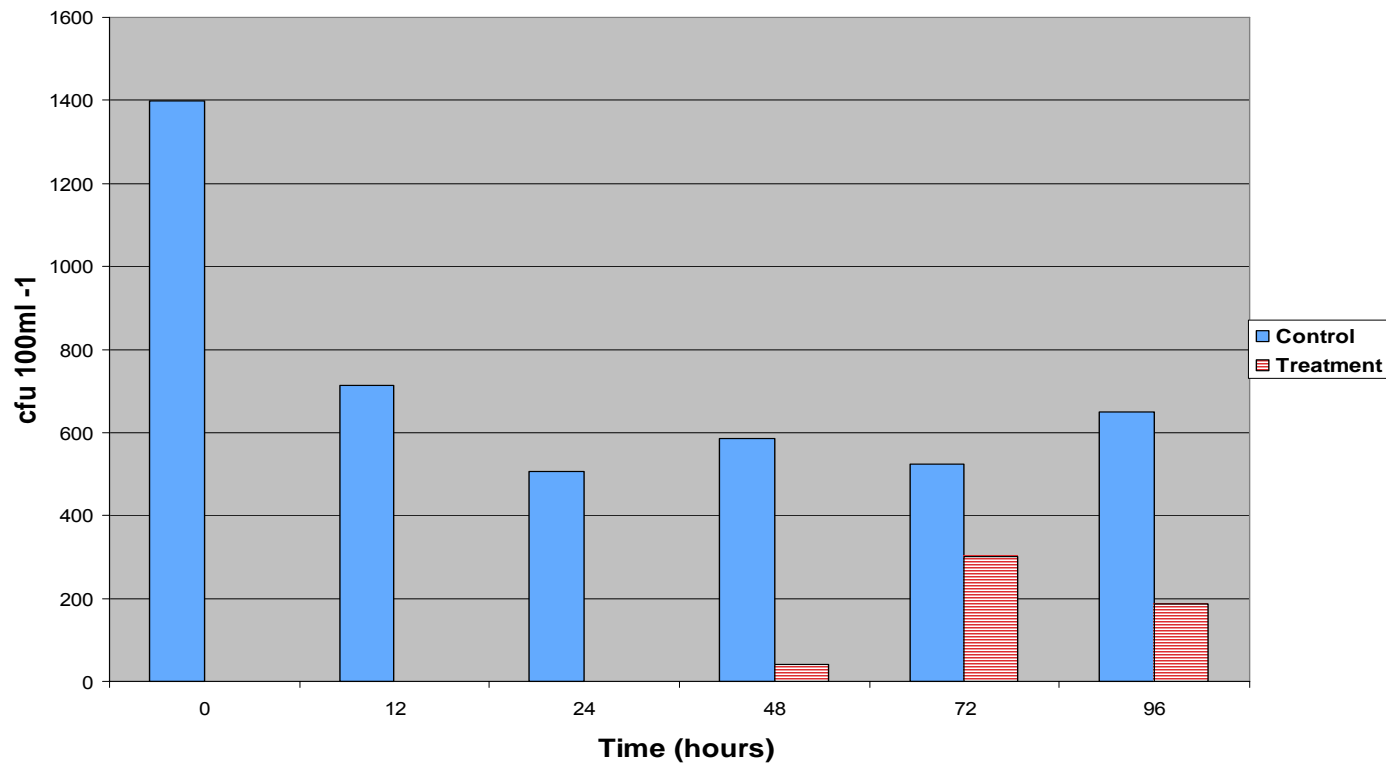

Test Results

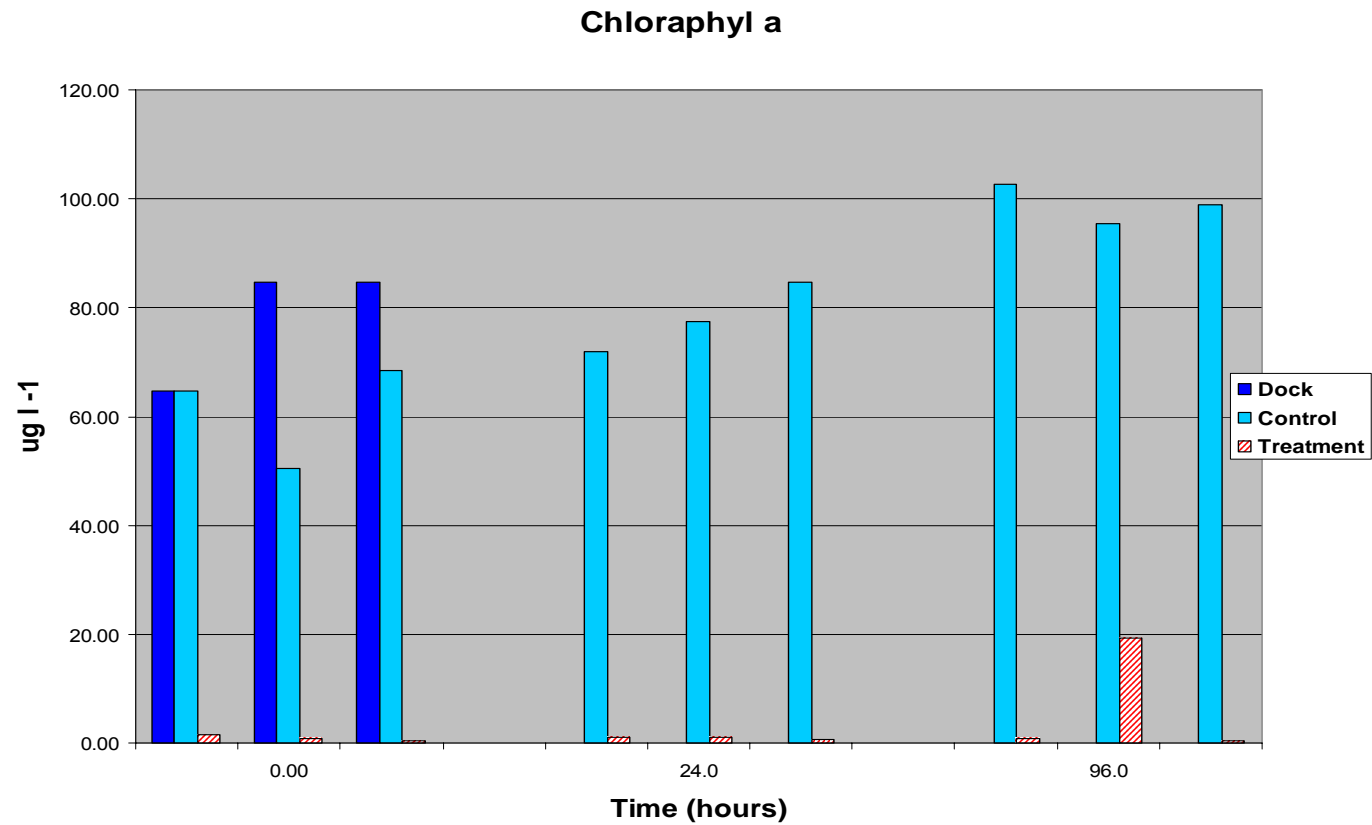

Test Results

Chlorophyl a

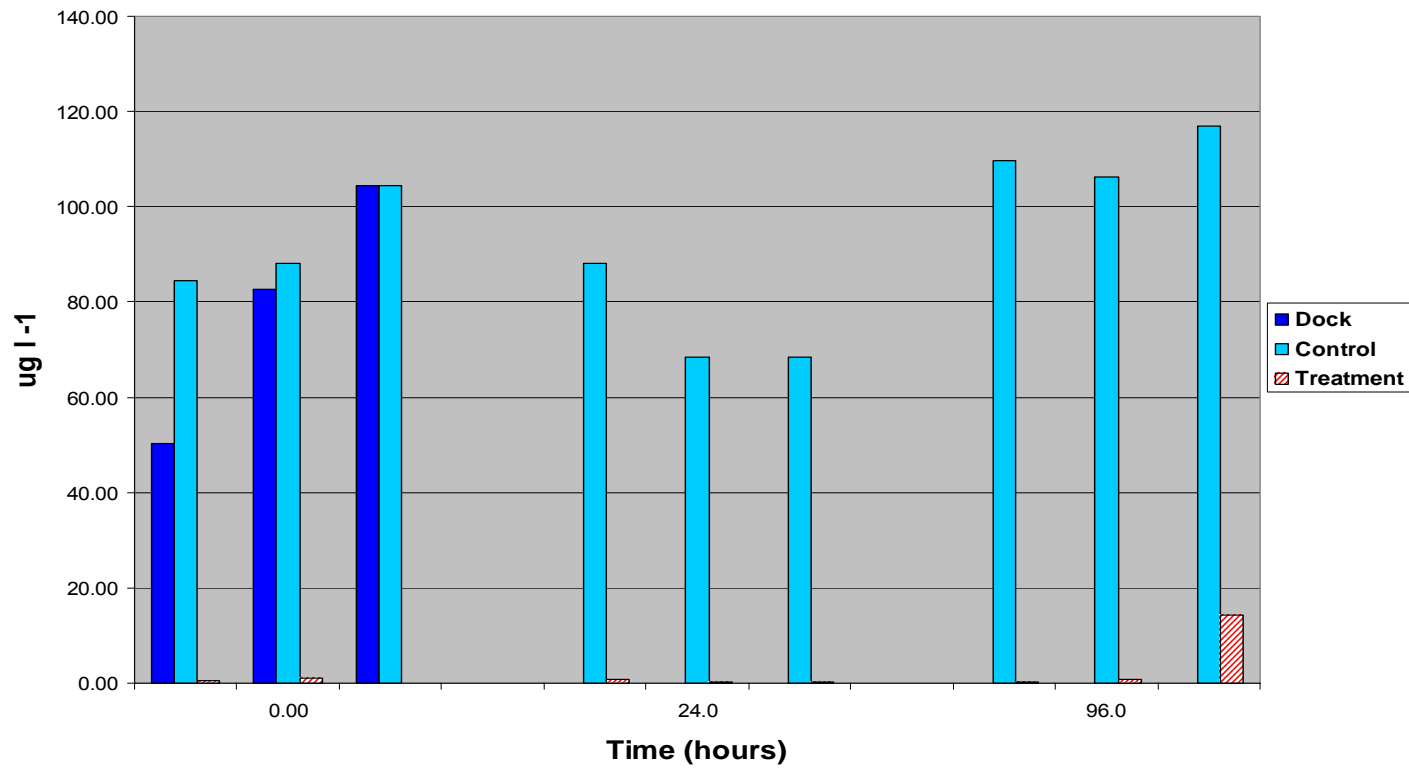



Summary



Summary

- Systems installed without interruption of schedule or cargo operations
- Installations approved by Lloyd's Register, ABS
- Shipboard testing during normal ballasting operations, fully automated
- Treatment is highly effective on all organisms
- Re-growth addressed with subsequent treatments



Summary

- Ecochlor has submitted two applications for the USCG STEP
- Ecochlor is submitting a request for Interim Approval to Washington State
- Additional testing by the University of Rhode Island planned for both vessels in 2006



14th International Conference on Aquatic Invasive Species



**Key Biscayne Florida
USA**



**Two Shipboard Demonstration of Chlorine d
Dioxide to Control AIS:
Swedish flagged Ro/Ro Containership
And a US Flagged ITB Bulker**



The Safe and Economical Treatment
of Ballast Water



Ecochlor System



Installed on the M/V Moku Pahu